

OPERATING INSTRUCTIONS

MODEL 4&6 NAMEPLATE DETAIL PRESSES

EASY FOUR-STEP OPERATION

1. Center the Nameplate on the table. Press the clamp handle down to slide the nameplate into a new position. Release the clamp handle to lock it in place. The clamp is fastened to a sliding rectangle (table gauge assembly), which is tightened by means of a small thumb screw. The entire table can be indexed by pressing the space button at the front of the unit.

CAUTION: When indexing the table, be sure to grasp the table lightly with your left hand; the table operates like a typewriter carriage and damage will result if it is allowed to slam against the limit screw.

2. Spin the character dial to select the desired number or letter.

3. Set marking depth by turning the depth adjustment screw. First, set depth until dial contacts the nameplate. Then remove the plate and make another 1-1/2 counter clockwise turn to indent the plate. Turning the screw clockwise makes the impression shallower.

4. Move operating handle forward firmly to make impressions. If the mark is not deep enough, adjust the depth setting. The handle will return to its original position, which automatically indexes the table one notch to the left, placing the nameplate in position for the next character. Move the handle forward to backward halfway to leave a blank space or a space between words.

CAUTION: Forcing the operating handle down or back will cause damage to the machine.

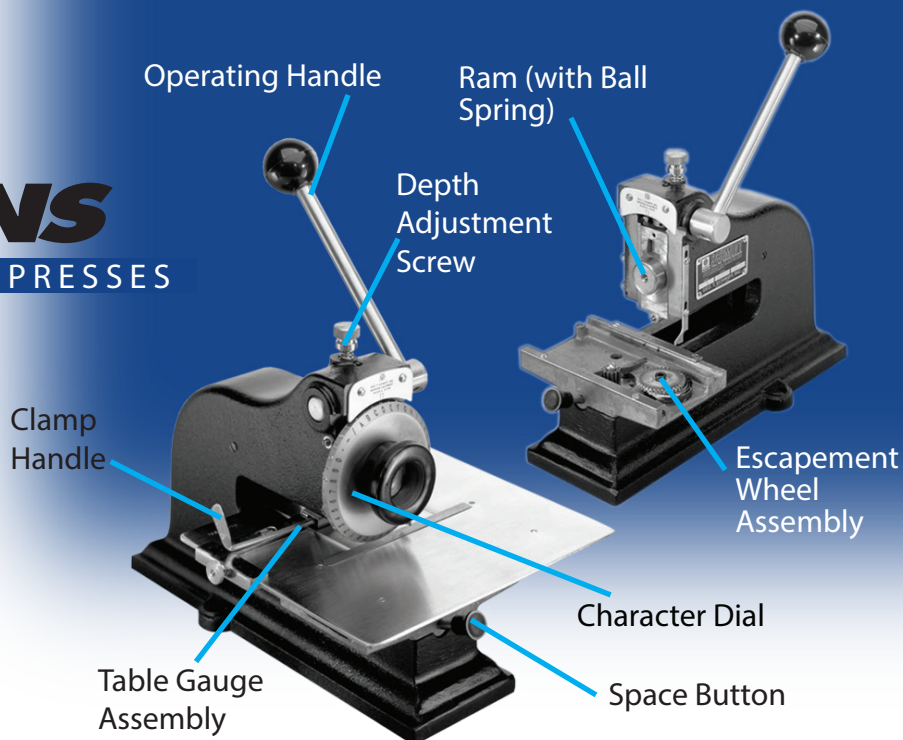

Operating Flexibility. Your SCHMIDT Nameplate detail press can be operated efficiently by pulling the operating handle from a sitting position or by pushing the operating handle from a standing position. Just remember to bring the operating handle to the neutral position - and not beyond.

To set the plate for stamping a new line of another panel, simply move the table gauge forward or back to center the locating pointer. For added flexibility, the table gauge can be placed on the right edge of the table. The clamp is then in front of the dial and plates are gripped at the bottom, allowing the machine to stamp at the extreme top edge. With the gauge in this position, the throat capacity is also increased to 4.5 inches.

CHANGING THE MARKING DIAL:

1. Remove screw in the center of the dial and take off dial, knob and pointer. Place new dial and pointer in position and tighten into place with retaining screw.
2. Slide table to extreme right and remove table limit screw. Return table to left to expose spacing mechanism. Remove escapement wheel and replace with one that matches correct dial size. Replace the limit screw.
3. Return table to marking position.

EXTRA DIALS: All dial assemblies are interchangeable and include Knob, Pointer and Escapement Wheel. Sizes available include 3/32", 1/8", 3/16" and 1/4"

SCHMIDT

(800) 323-1332 (847) 647-7117

www.gtschmidt.com

PARTS LIST

MODEL 4&6 NAMEPLATE DETAIL PRESSES

Diagram	SKU	Part Name
1a.	033025	Table - Model 4
1b. (ns)	033026	Table - Model 6
2.	033023	Table Slide Assembly
3.	033062	Drum Gear
4.	033080	Trigger Spring
5.	033085	Pawl Spring
6.	033031	Stop Arm
7.	033033	Pawl Assembly
8.	033020	Space Button Assembly
9a.	033058	Table Spring - Model 4
9b. (ns)	033059	Table Spring - Model 6
10.	033076	Anvil
11.	033060	Spacing Rack
12.	033022	Front Guide
13.	033027	Rear Guide
14.	033082	Connector Link
15.	033097	Table Gauge Assembly
16.	033091	Table Gauge Nut
17.	054791	Spring Clamp
18.	033088	Clamp Handle
19.	033090	Table Gauge Bar

Diagram	SKU	Part Name
20.	033084	Gauge Lock
21.	033147	Crank Spring
22.	033046	Bell Crank - Model 4
23.	033047	Bell Crank - Model 6
24.	033045	Safety Spring
25.	033086	Depth Adjustment Screw
26.	Size*	Marking Dial Assembly
27.	033092	Marking Dial Rubber Knob
28.	Size*	Pointer
29.	Size*	Escapement Wheel
30.	033093	Ram with Ball Spring
31.	033074	Plunger Spring
32.	033063	Ball Spring
33.	033077	Capstan Screw
34.	033081	Washer
35.	033079	Operating Handle Assembly
36.	033078	Cam
37.	033072	Nameplate
38.	033073	Gib
39.	054082	Truarc Ring

*Must have character dial size when ordering
(ns) stands for Not Shown on diagram

AVAILABLE DIAL SIZES

3/32", 1/8", 3/16" or 1/4"

Sharp Face Characters Only

All dials assemblies are interchangeable and include: dial, knob, pointer and escapement wheel.

Machines, Dials, and Replacement Parts can be purchased online at:
<https://secure.gtschmidt.com/sunshop/>

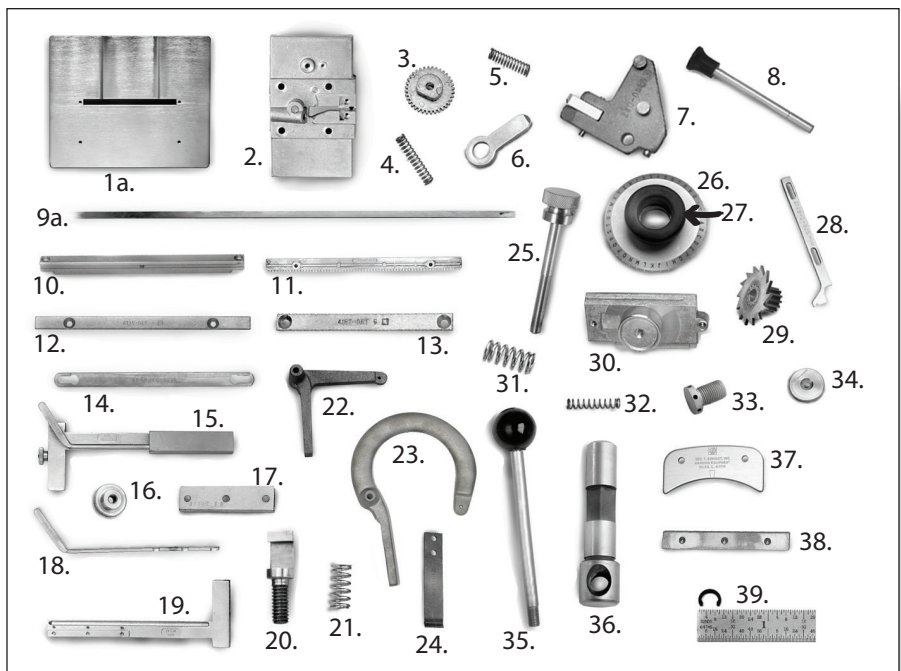

Images are not to scale, smaller parts have been enlarged to show detail

SCHMIDT

6151 W Howard Street Niles, IL 60714

847-647-7117 | 800-323-1332

www.gtschmidt.com



ISO 9001: 2015