

MOTOR "SCHARADER BELLOWS" # B821-30205  
 2 1/2" BORE 6" STROKE (S" MAX IMPACT  
 STROKE 1" CUSHION) W/VALVE # B8022101  
 115 V/60 C.T. # BR02 CENTER FLANGE MFG.  
 LESS STEEL DOWN TRANSFORMER

LINE CORD TO 2 PB BOX  
 (SEE DIM. 8600-59)

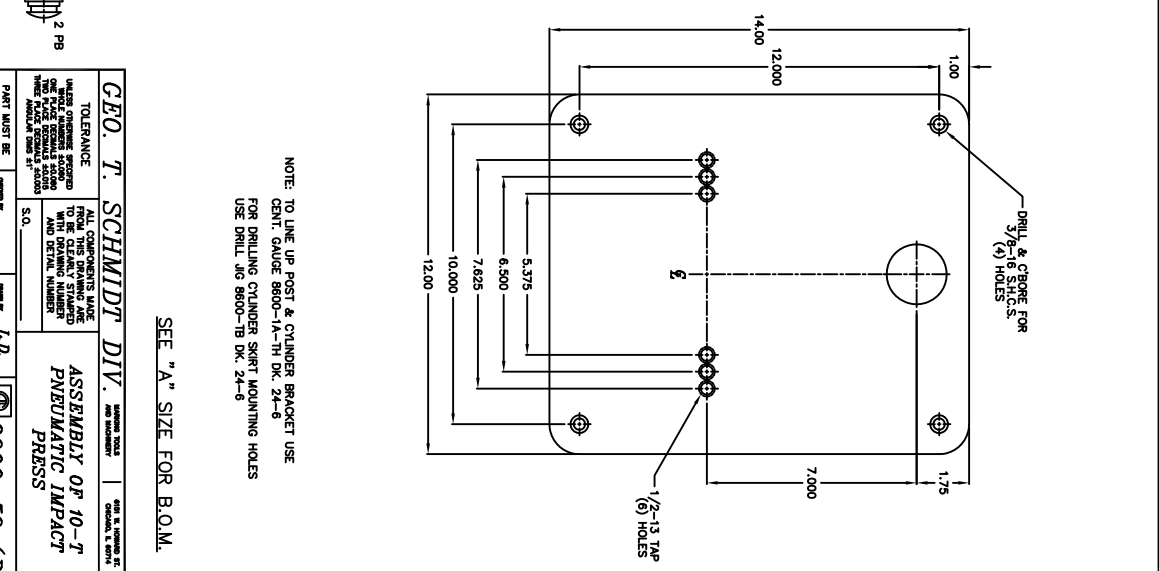
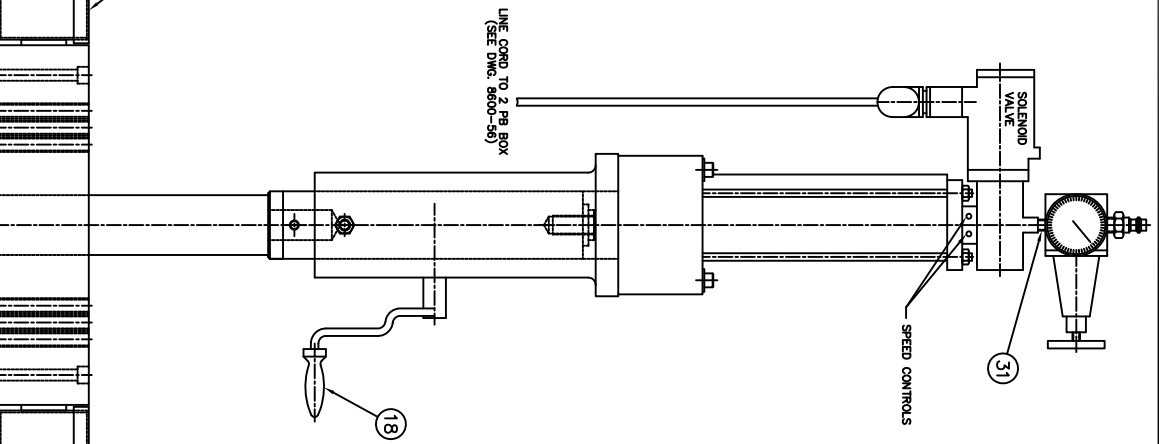

**GEO. T. SCHMIDT DIV.** AN IRVING-CLOUD COMPANY

**ASSEMBLY OF 10-T PNEUMATIC IMPACT PRESS**

ALL COMPONENTS MAKE FROM THIS DRAWING ARE TO BE IDENTIFIED BY THE DRAWING NUMBER AND DETAIL NUMBER S.O.

UNLESS OTHERWISE SPECIFIED ALL DIMENSIONS ARE TO BE IN INCHES AND DECIMALS THEREOF. DIMENSIONS IN PARENTHESES ARE FOR INFORMATION ONLY.

DATE: 01/12/93

SCALE: 1:2

DESIGNER: L.D.

8600-59 (D)

SEE "A" SIZE FOR B.O.M.